

(No Model.)

W. SANDIFORD.
LATHE DOG.

No. 602,606.

Patented Apr. 19, 1898.

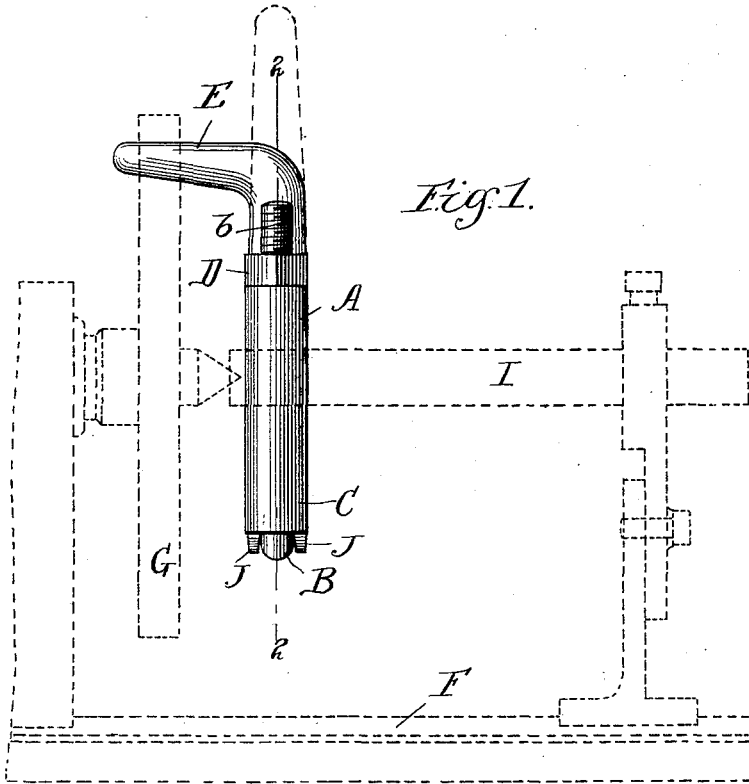

Fig. 1.

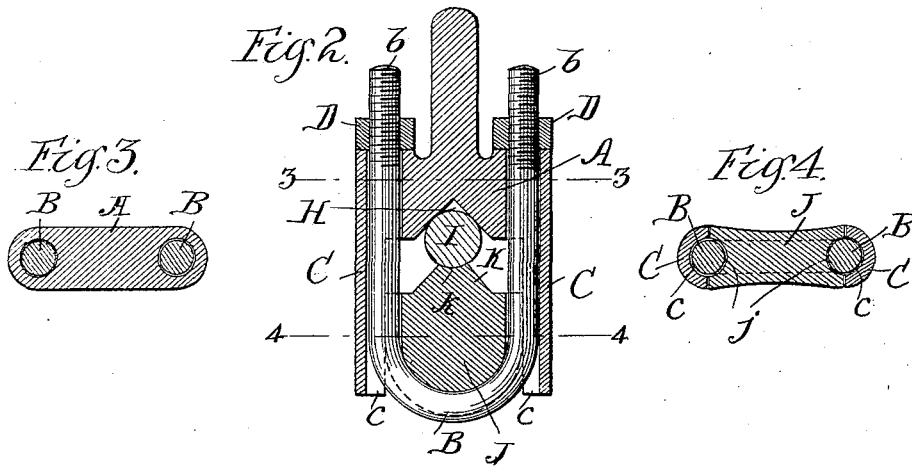

Fig. 2.

Fig. 3.

Fig. 4.

Witnesses.
 Wm. N. Rheem
 Wm. A. Bell

Inventor
 William Sandiford
 by Raymond F. Crossland
 Atty's

UNITED STATES PATENT OFFICE.

WILLIAM SANDIFORD, OF CHICAGO, ILLINOIS, ASSIGNOR OF ONE-HALF TO
PETER M. KIMMEY, OF SAME PLACE.

LATHE-DOG.

SPECIFICATION forming part of Letters Patent No. 602,606, dated April 19, 1898.

Application filed June 14, 1897. Serial No. 640,627. (No model.)

To all whom it may concern:

Be it known that I, WILLIAM SANDIFORD, a citizen of the United States, residing at Chicago, in the county of Cook and State of Illinois, have invented certain new and useful Improvements in Lathe-Dogs, of which the following is a full, clear, and exact description, reference being had to the accompanying drawings, forming a part of this specification.

My invention relates to certain new and useful improvements in lathe-dogs; and its primary object is to provide a device of this character which will be free of parts projecting from its sides and ends to catch the clothing of the operator and draw him against the lathe.

A further object of the invention is to simplify and improve the construction of a lathe-dog whereby greater efficiency of operation is obtained and quicker adjustments made possible.

With these and other ends in view my invention consists in the construction and arrangements of parts hereinafter described, and shown in the accompanying drawings, in which—

Figure 1 shows my improved lathe-dog in position on so much of a lathe as is necessary for the full understanding of the invention, the parts of the lathe being illustrated in broken lines. Fig. 2 is a central sectional view through the lathe-dog on the line 2 2 of Fig. 1. Fig. 3 is a transverse sectional view on the line 3 3 of Fig. 2. Fig. 4 is a cross-sectional view on the line 4 4 of Fig. 2.

In the drawings like letters of reference denote corresponding parts in all the figures, referring to which, A designates the body of my improved lathe-dog, and it is provided with two openings to receive the ends of the clip or bail B, these openings being also extended in semicircular form throughout the extensions C on the body, as indicated by *c* in Fig. 2. The clip or bail is provided with threaded ends *b*, which project above the body of the dog and receive nuts D, which rest upon the body. The body is also provided with a shank E, as shown in Fig. 1; but if it is desired this shank may be turned

into an upright position, as indicated in dotted lines, to adapt the device for use as a tool-holder, in which case the projecting shank would engage the base-plate F of the lathe instead of engaging the face-plate G thereof.

The body A is provided with an angular recess H to receive the work or shaft I, and a clamping-block J is supported and arranged within the bend of the U bolt or clip B, being provided with a groove *j* to receive said bolt or clip. This clamping-block has a projection K, provided with a segmental face *k* to engage the shaft I, so that the shaft will be tightly clamped between the body of the dog and the clamping-block by means of the U bolt or clip.

It will be observed that my improved dog is free from projecting parts below the bend of the U bolt or clip, which are common to ordinary lathe-dogs and which frequently catch in the clothing of the workmen and draw them against the rapidly-revolving parts of the lathe. By adjusting the nuts D the U-bolt can be readily moved to force the clamping-block tightly against the shaft or work I, which rests in the recess H of the body. By this construction it is possible also to clamp the work in a perfectly-true position, as any adjustment of one member of the U-bolt will operate likewise to adjust the other member thereof, and so when the nuts D are loosened the work can be immediately loosened or the clamping-block adjusted by moving one member of the U-bolt. The clamping-block is provided with a peripheral groove *j* to receive the U-bolt, and it is therefore always held in its proper operative position without danger of becoming displaced in any manner. The extensions C, with the semicircular grooves *c* therein, which grooves form continuations of the openings in the body A, constitute guides for the U-bolt in its operations and adjustments, and they also protect the bolt.

Having thus fully described my invention, 95 what I claim, and desire to secure by Letters Patent, is—

1. In a lathe-dog, the combination with a body provided with extensions, of a U bolt or clip having its members arranged to oper-

100

ate in openings in said body and extensions,
a locking-block supported and carried in the
bend of said **U** bolt or clip and nuts operat-
ing on the threaded ends of the **U** bolt or clip
5 and against the body of the dog, substan-
tially as and for the purpose described.

2. In a lathe-dog, the combination with a
body having side extensions and openings
through said body and in semicircular form
10 through the extensions, of a **U**-bolt having its
members arranged to operate in the openings
in the body and extensions, nuts adapted to
operate on the threaded ends of said **U**-bolt
and against the body of the dog and a lock-
15 ing-block supported by said **U**-bolt and pro-

vided with a peripheral groove to receive the
same, substantially as described.

3. In a lathe-dog, the combination with a
body having side extensions and an angular
recess in its face to engage the work, of a **U**- 20
bolt having its members arranged to operate
in openings through the body and extensions,
a locking-block supported in the bend of said
U-bolt and a projection on said locking-block
having a segmental face to engage the work, 25
substantially as described.

WILLIAM SANDIFORD.

Witnesses:

RUDOLPH F. RYMER,
FRED GADDIS.